

# YA.0519.00A.CLG - XYA-010

# CLG CLUTCH FOR YAMAHA YZ 65 2019

## ASSEMBLY INSTRUCTION

The hub/insert group is supplied pre-assembled. **DO NOT REMOVE THE HUMMERING INSERT FROM THE HUB LOCATIONS.**

**WARNING:** Between the original basket and the hub (YA.0419.02A.CLG) you must keep the washer of the original clutch, otherwise there could be generated malfunctions and/or damage to the parts.

Remove the original clutch group, taking care of nut washer, nut and friction clutch discs. You will use it again on the CLG clutch. Install the hub (YA.0419.02A.CLG).

Start assembling the clutch discs on the hub by first inserting an STM steel disc (YA.0419.05A.CLG) and then alternating the OEM friction disc. The sequence will end with an OEM friction disc. The CLG steel disc (YA.0419.05A.CLG) have niches, take care to couple them correctly in the hub as shown in the image below (1).

The total height of the disc pack must be 25.2mm ± 0.2mm.

**ATTENTION:** if with the original disc pack there were two rings (one of them conical), positioned inside a friction disc, set them aside and **DO NOT use them when reassembling the disc pack on the CLG clutch.**

Install the washer nut under the nut and the original nut, tightening to the tightening torque indicated by the manufacturer. Hold on the hub during the nut tightening phase, pressing firmly on the disc pack or using the appropriate assembly key where available.

Install the pressure plate (YA.0519.04A.CLG) taking care to correctly match the latter's hole with the hub protrusions as shown in the image below (2).

Install the Ø105 spring (0S1105) by placing it on the appropriate seat of the pressure plate.

Install the contrast disc (YA.0419.03B.CLG) taking care to correctly position on the petals of the Ø105 spring. The contrast disc has two positions. Using the screws provided in the packaging (901VT050), tighten the contrast disc using position 1 with a new disc pack while position 2 with a worn disc pack of 0.4mm.

This will allow us to maintain the same load as the spring even when the disc pack is worn.

**When assembly is complete, repeatedly activate the clutch lever checking that it performs the correct opening and closing movement, then reassemble the crankcase.**

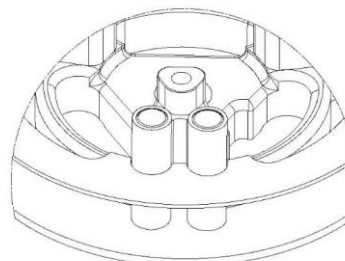
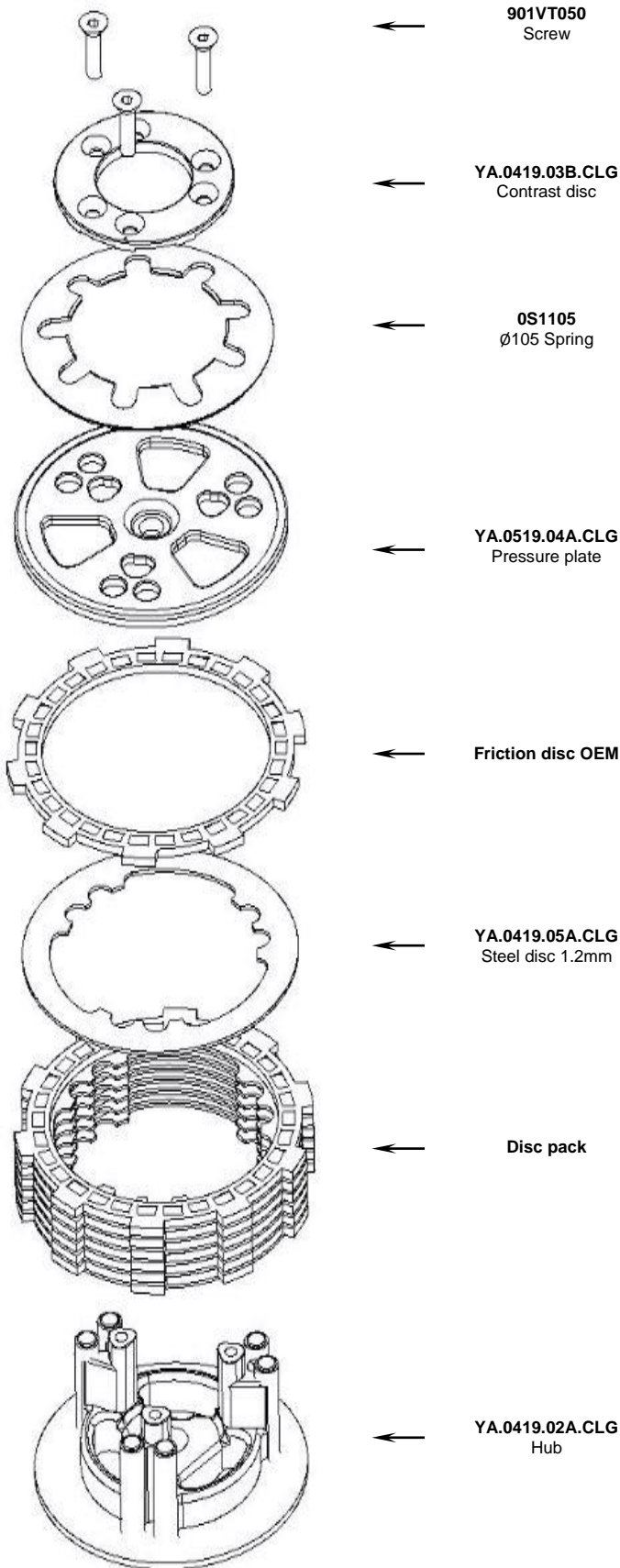

(1)

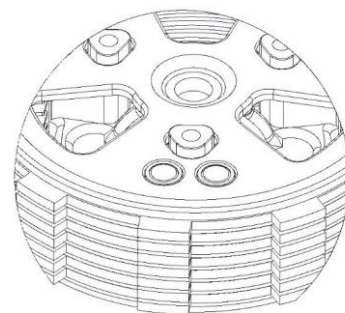

(2)

### GENERAL SAFETY REGULATIONS

- IN THIS SHEET ARE REPORTED THE DIRECTIONS TO PERFORM CORRECTLY THE CLUTCH ASSEMBLY OPERATIONS.
- STM RESERVES THE RIGHT, WITHOUT NOTICE, TO INTRODUCE ANY TECHNICAL CHANGE WHENEVER DEEMED IT TO BE NECESSARY TO IMPROVE FUNCTION AND QUALITY OF THE PRODUCTS.
- ASSEMBLY OPERATIONS MUST BE PERFORMED BY A SKILLED TECHNICIAN AND MUST BE SCRUPULOUSLY OBSERVED.
- BEFORE MOUNTING THE CLUTCH MAKE A COMPLETE INSPECTION OF THE MOTORBIKE COMPONENTS, IN ORDER TO VERIFY THE POSSIBLE PRESENCE OF FAULTS OR ANOMALIES ON THE VEHICLE.
- MAKE SURE THAT THERE ARE NO MISSING/DAMAGED PARTS IN THE CLUTCH KIT.
- SOME PARTS OF THE CLUTCH AND ITS COMPONENTS CAN HAVE SHARP SURFACE: HANDLE WITH CARE.
- SOME COMPONENTS OF THE CLUTCH, BECAUSE OF THEIR SMALL DIMENSIONS CAN BE SWALLOWED: KEEP AWAY FROM CHILDREN.

**STM ITALY**  
Via A. Olivetti 15 - 10020 - Riva presso Chieri (TO)  
www.stmitaly.com - contact@stmitaly.com

